

HIPM Plastic product Design Evaluation

* Required

7

21

1. ExtendedForms Id (skip this field)
DO NOT EDIT this field or your score will not recorded.

2. Name of Candidate

Samvesh Pradip Wagh

3. Which of following materials are used in Consumer Durable products?

Mark only one oval.

- PP
- HIPS
- ABS
- POM
- Nylon
- All of Above

X

4. Which of below material is semi crystalline?

Mark only one oval.

- PP
- ABS
- PC
- All of Above

X

5. What is Tensile modulus range value of HIPS at room temperature?

Mark only one oval.

- 700 - 900 MPa
 1000 - 1600 Mpa
 1800-2200 Mpa
 3500 - 4000 Mpa

X

6. What is Tensile modulus range value of PP at room temperature?

Mark only one oval.

- 700 - 900 MPa
 1000 - 1400 Mpa
 1800-2200 Mpa
 3500 - 4000 Mpa

X

7. What is melting temperature range value of PP material?

Mark only one oval.

- 70-100 Deg C
 140- 190 Deg C
 200 - 264 Deg C
 320 - 400 Deg C

X

8. What is meaning of HDT?

Mark only one oval.

- Heat Deflection Temperature
 Highly Defined Texture
 High Density Testing
 None of above

1

9. How much material shrinkage value considered for HIPS material in percentage value?

Mark only one oval.

0.2 - 0.8

1.1 - 1.4

2.2 - 3.2

3.4 - 3.8

X

10. What is typical Nominal wall thickness range for injection moulding parts in mm?

Mark only one oval.

0.2 - 0.9

1 - 1.5

2 - 5

5 - 9

/

1

11. Below figure shows Core and Cavity, which of following statement is true?

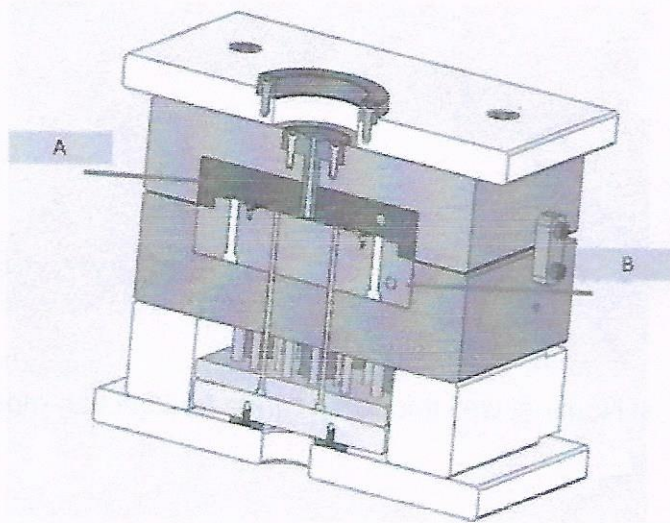

Mark only one oval.

- A is Cavity and B is Core
- B is Cavity and A is Core
- Both above statements are wrong
- Both above statements are right

11

12. Refereeing below figure, which of following statement is true, when Designing the Bosses in injection molding?

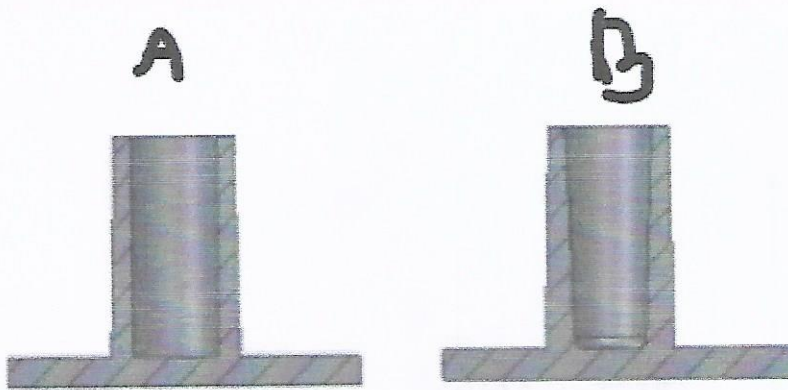

Mark only one oval.

- Both A and B both Boss design are correct
- A Boss design is only correct
- B Boss design is only correct
- Both A and B both Boss design are NOT correct

1

13. What should be ideal wall thickness for Bosses with respect to nominal thickness? (Refer below image)

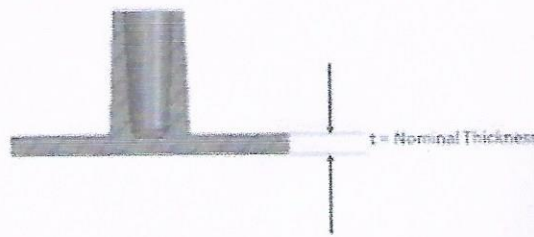

Mark only one oval.

- $0.2 * t$
- $0.6 * t$
- $1.2 * t$
- $1.6 * t$

X

14. Referring below figure, what is ideal rib thickness? where T is nominal base thickness and t is Rib thickness

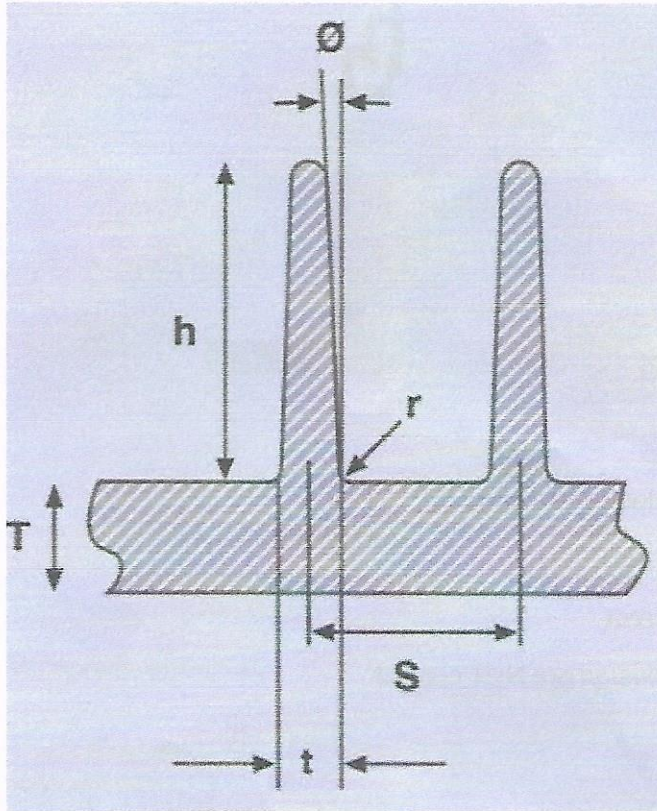

Mark only one oval.

$0.25 * T$

$0.6 * T$

$0.8 * T$

$1.2 * T$

15. Referring below figure, what is ideal rib height? where T is nominal base thickness and h is Rib height

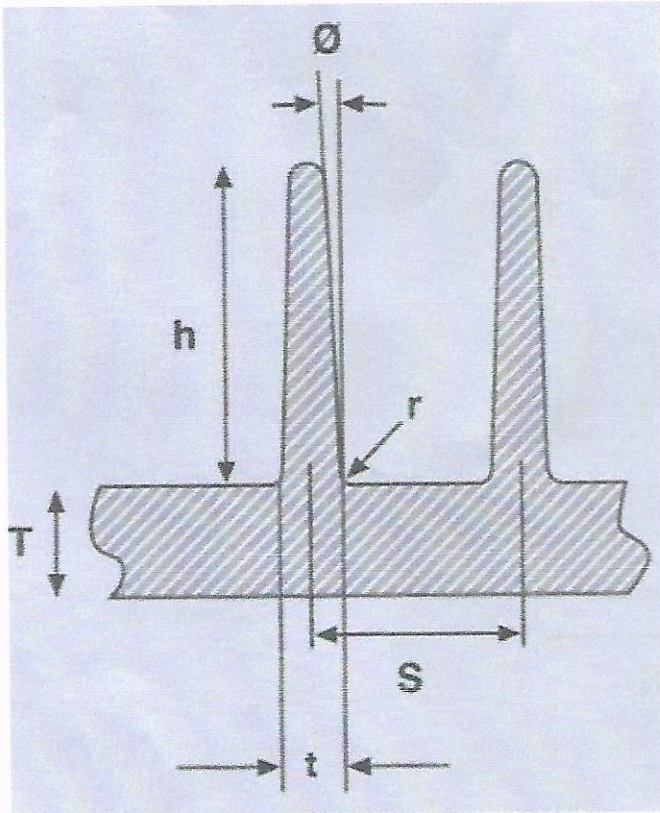

Mark only one oval.

- $3 * T < h$
 $3 * T > h$ ✗
 $4.8 * T = h$
 None of above

16. Referring below figure, what is ideal distance between two ribs? where T is nominal base thickness and S is ideal distance between the ribs

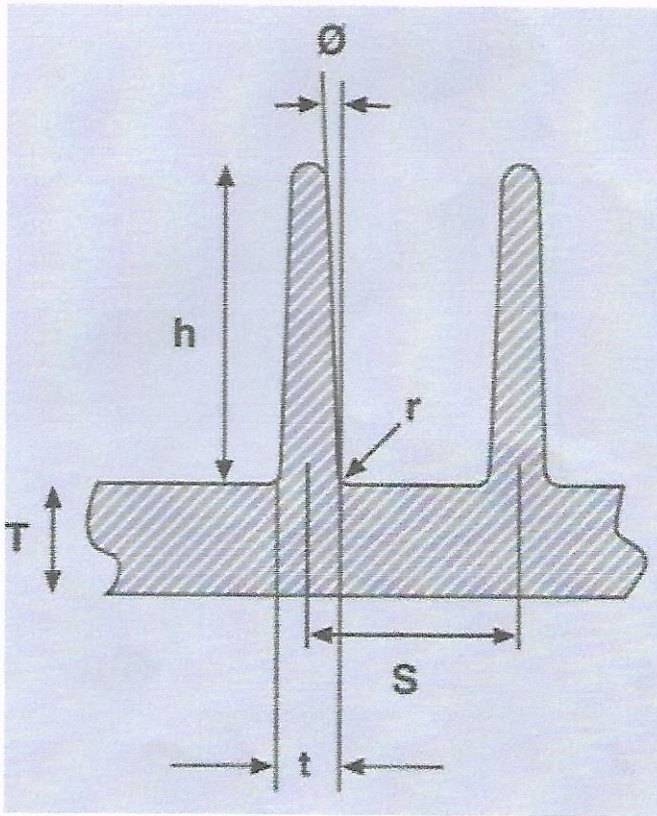

Mark only one oval.

- $2 * T < S$
- $2 * T > S$
- $1.2 * T = S$
- $1.6 * T = S$



17. Referring to below figure, what is true about the Locators?

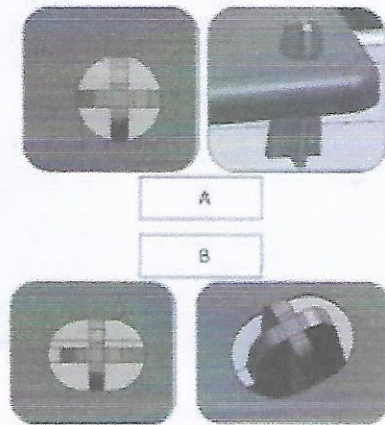

Mark only one oval.

- A is 2 way locator whereas B is 4 way locator
- A is 4 way locator whereas B is 2 way locator
- A and B are 4 way locators
- A and B are 2 way locators

18. Referring to below figure, what is the name of defect?

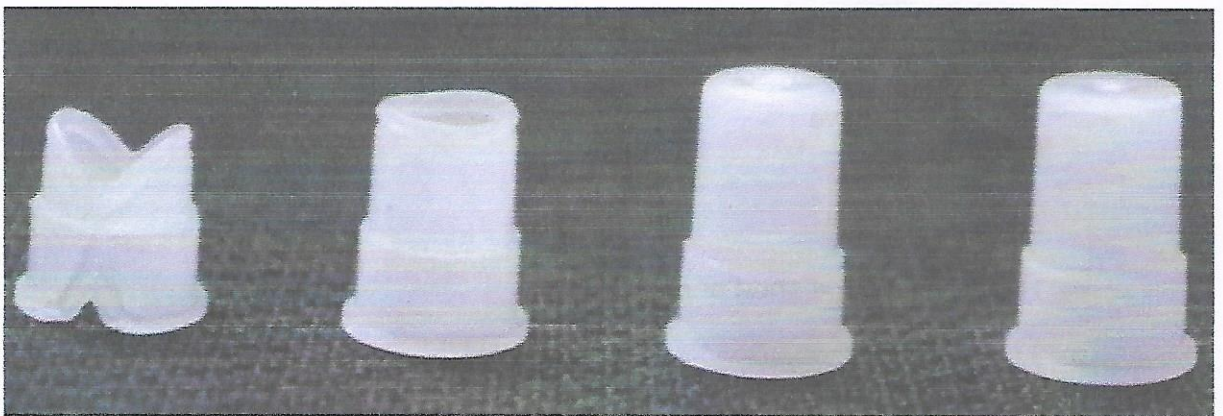

Mark only one oval.

- Flow Hesitation
- Short-shot
- Weld line
- sink mark

19. Referring to below figure, what is the name of defect?

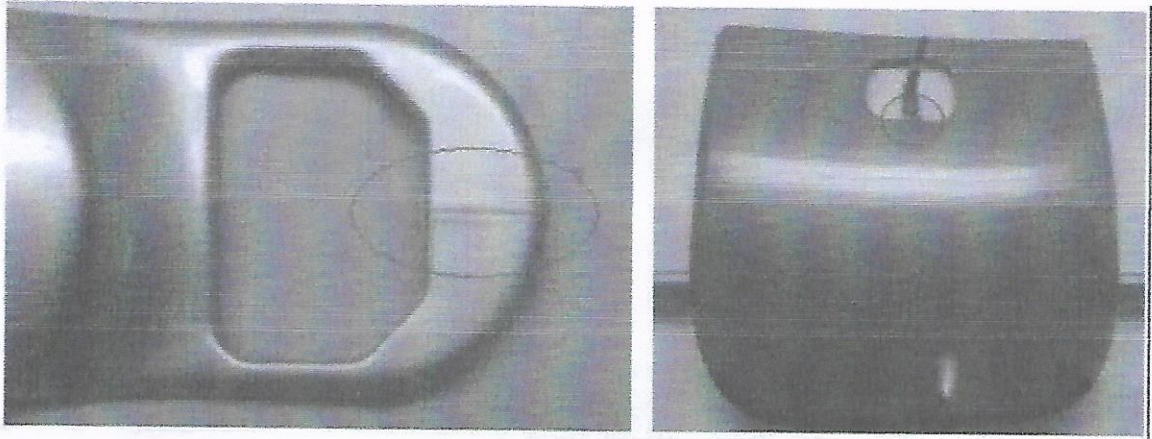

Mark only one oval.

- Sinkmark
- Weldline
- flow hesitation
- Air traps

20. How to avoid the weld lines defects?

Mark only one oval.

- Change the gate positions
- Change the part thickness.
- Increase melt and mold temperature. This will allow the flow fronts to interfuse more.
- All of Above

21. How to avoid the short shot defects?

Mark only one oval.

- Avoid hesitation.
- Eliminate air traps
- Increase mold and melt temperature
- All of Above

22. Which of following statement is true for defining texture for injection molding?

Mark only one oval.

- Normally 1.5 deg additional to normal draft for 0.025 mm depth of texture
- Normally 1.5 deg subtraction from normal draft for 0.025 mm depth of texture
- Normally 0.15 deg additional to normal draft for 0.025 mm depth of texture
- None of above



23. Referencing to below Figure, Explain the GD&T symbols

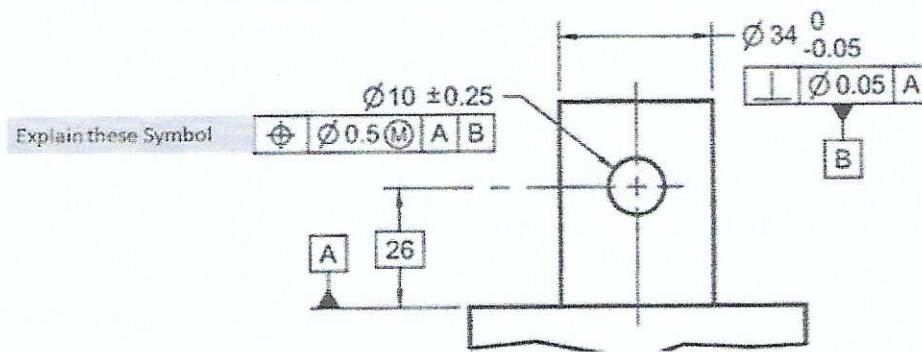

∅ - Diameter ✓
 ⊕ - Position ✓
 [A] - Datum ✓
 ⊥ - Perpendicular ✓
 [B] - Datum ✓

24. Quilgo Submission ID (do not edit) *

⚠ DO NOT EDIT this field or your time will not be recorded.